

Diocese of Sheffield Churchyard Rules

Revised 2024

Finningley, Holy Trinity & St Oswald



The purpose of these Rules is to ensure that churchyards are places that exude respect for those who have died and comfort to those whose loved ones are buried and commemorated in that place. They should be an oasis for their communities, provide a sense of history and be a proper setting for the church and the memorials. They should be places where people can come to pray, to remember and, wherever possible, to find beauty, quiet and peace.

Introduction

Churchyards are consecrated and fall under the authority of the Bishop of Sheffield. That authority is exercised by the Chancellor of the Diocese. She is the ecclesiastical judge of the Diocese and is ultimately responsible for all decisions affecting Churchyards.

Incumbents (the Minister) of each church are the custodians of the church buildings and churchyards and for Finningley the Incumbent is the Rev Neil Redeyoff. Responsibility for the appearance, care and maintenance of the churchyard lies with the Parochial Church Council (PCC).

It is not practical or necessary for every decision concerning a churchyard to be made by the Chancellor via a legal or Court process and so Chancellors generally delegate their authority to Incumbents.

Some Important Preliminaries

We do understand that having to face these rules at what is a very sad and challenging time is perhaps a little daunting. Nonetheless, it would be an unkindness to you not to be clear about what is permitted and what is not permitted.

Therefore the words that follow may seem somewhat forthright, but will hopefully explain the regulations with brevity and clarity. However, we really do want to support you at this time, and therefore invite you to contact our Incumbent, Rev Neil Redeyoff, with any questions or concerns and he will be very happy to offer you all the help that he can.

There are four fundamental aspects which everyone needs to be aware of, and they are as follows.

1. No one has absolute free choice to install any memorial they wish into a churchyard. Memorials must be within the rules that follow or permitted by a decision of the Chancellor. Memorials installed without permission are unlawful and may be removed by order of the Court. Any new memorial must be erected to comply with the current British Standard BS 8415:2018.
2. The Incumbent, Rev Neil Redeyoff, has no authority to permit something which is outside the rules. If anyone wishes to instal a memorial which is outside the rules they should petition (make an application) for a faculty (legal permission) from the Consistory Court of the Diocese. The Diocesan Registry can advise on the paperwork which needs to be completed to make a faculty application to the Consistory Court. Application forms may be obtained from the Registry, or downloaded from the Diocese of Sheffield website. Our Incumbent will also be very happy to offer support.
3. There can be some confusion around ownership of a grave, so for clarity the allocation of a plot for burial does not confer ownership of the plot. This belongs to the church and remains subject to the regulation and law which apply to churches and churchyards.
4. The Church regards burial as a final act theologically and, save for exceptional circumstances with the Court's permission, there is no prospect, at a later date, of remains being exhumed and reburied elsewhere.

The Regulations

What follows is a summary of the Churchyard Regulation for Sheffield Diocese. The full rules, along with more information, contact details, application forms and contact details can be found here <https://www.sheffield.anglican.org/the-diocesan-registry/>

The Procedure

1. Decisions about memorials may only be taken by the Incumbent.
2. The introduction of a memorial at the site of a burial can only take place after six months have passed from the burial. In some locations and at some times, the six-month period may need to be longer by reason of the condition of the ground and soil in the churchyard. In the interim period a temporary marker may be erected (in the form of a wooden cross, max. 450 mm x 300 mm). It may be left in place for no longer than six months. Regardless of whether a permanent memorial is to be erected or not, temporary markers may be removed after six months have expired.
3. Applications to erect a memorial or place anything whatsoever or do any works in the churchyard should be made in writing to the Incumbent on the Memorial Permit Form issued by the Diocese which is available here <https://www.sheffield.anglican.org/the-diocesan-registry/> The application should include a full description of what is proposed including outline drawings and measurements and details of the wording of the inscription.
4. We also advise that it is sensible not to enter into any binding agreement with a memorial mason until permission for what is proposed has been obtained. It should be pointed out that the presence of pre-existing memorials in a given churchyard does not constitute a permissive precedent.

Generally

5. A headstone is a public statement about the person who is being commemorated. Making the right choice of material, design and inscription is important for all the relatives and friends of the person but also to the wider community because of the impact which the headstone may have upon the overall appearance of the churchyard.

These Rules should not discourage originality or high standards of design. Whilst it is good to use local craftsmen and artists there are alternatives that bereaved people may wish to consider. See for example the National Association of Memorial Masons [www.namm.org.uk] or Memorials by Artists [<https://www.letteringartstrust.org.uk/memorials>].

Location of graves

6. No burial may be permitted and no memorial erected within 3.5 metres of the walls of the church except where authorised by faculty. This prohibition includes the interment of cremated remains and the associated memorials

Reservation of grave spaces

7. A grave space may only be reserved by faculty, any other form of reservation has no legal effect. To reserve a grave space within a churchyard, a petition for faculty (i.e. an application) must be submitted to the Consistory Court. A faculty is also required for second or subsequent burials in family plots.

Further information and application forms can be downloaded from the Diocese of Sheffield website or obtained from the Registry. Completed forms, together with the requisite fee must be returned to the Registry. A memorial in a reserved space requires the same permission as any other.

Reserving a grave space by faculty does not confer ownership of the plot reserved. A space, once reserved, must be clearly marked as such (i.e. 'Reserved. Smith') by churchwardens acting for the PCC.

Dimensions of Headstone

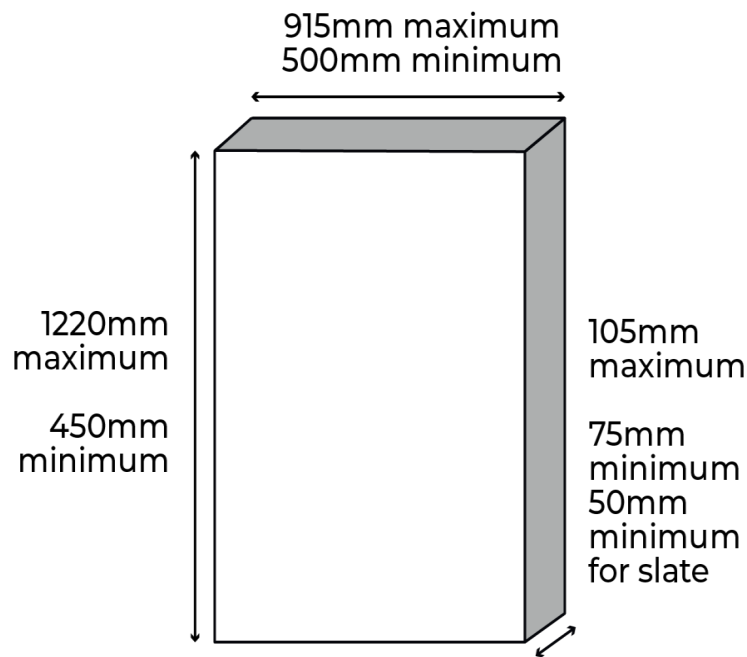

8. Headstones should measure:

- No more than 1220mm (4ft) high, measured from the surface of the ground;
- No more than 915mm (3ft) wide;
- No more than 105mm (4in) thick;
- No less than 450mm (1ft 6in) high;
- No less than 500mm (1ft 8in) wide;
- No less than 75mm (3in) thick (except in the case of slate memorials, which may be thinner but no less than 50mm (2in thick)).

These measurements are not intended to define standard proportions of memorials which may be of any dimensions within the given maximum and minimum.

Base and Foundation Slab

9. A headstone must be adequately secured in the ground to ensure that it is stable. A headstone may stand on a stone base, provided that it is an integral part of the design and does not project more than 105mm (4in) beyond the headstone in any direction, except where a receptacle for flowers is provided, in which case this may extend up to 210mm (8in) in front of the headstone. The maximum permissible width of a base is 915mm, the maximum depth (front to back) is 460mm and the maximum thickness is 155mm. Due regard should be paid to the nature of the ground and the problem of settlement; where a concrete sub-base is necessary for these reasons, it must be below the surface of the ground. Other methods of fixing the memorial in the ground are not discouraged, and the base of the memorial may be so shaped that it can be inserted directly into the ground at sufficient depth to ensure stability. The minimum size for a foundation in BS 8415 is 900mm x 450mm x 75 mm. Foundations must be laid below ground level.

Kerbstones

10. Kerbstones are not normally allowed. They may exceptionally be permitted by the Incumbent in parts of churchyards where kerbstones are already common in that area and the introduction of the proposed kerbstones would have no adverse effect on the maintenance of the churchyard.

Materials

11.

- All memorials should be made of natural stone. An unpolished surface is preferred but if a polished surface is permitted, this should be on the front and on the top surface of the base only.

- Stones traditionally used in local buildings, or stones closely similar to the colour and texture to that of the church, are to be preferred (i.e. sandstone, limestone, granite or slate).
- White marble, synthetic stone or plastic are not permitted.
- Although black granite is common in local authority cemeteries, black, blue or red granites, and granites darker than Rustenburg grey, are not traditional in churchyards and the Incumbent or Area Dean may only authorise them where they are already common in the part of the churchyard in which the proposed memorial is to be placed.

Design

12.

- Recommended shapes are as follows:

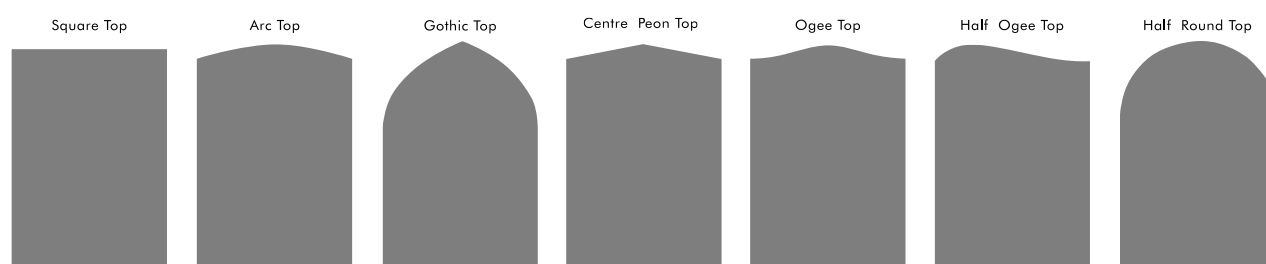

- Figure sculpture and other statuary can only be authorised by faculty;
- Headstones are not restricted to a rectangular shape. However, memorials in the shape of a heart or book can only be authorised by faculty;
- Railings, chains, chippings, fencing, and wooden edging are not permitted even by faculty.
- All lighting (including solar lighting) is prohibited.

-

Epitaphs and other inscriptions

13.

- a. The inscription on the memorial must contain the name of the deceased, the date of his or her death, and the date of birth or the age at death. Cardinal numbers are preferred for dates. Space permitting, all forenames may be present, or they may be replaced by initials. Titles and civil or military honours may also be included. The names of months should be written out in full. Relationships must be stated correctly. Relations should normally be limited to parents, children and spouse or partner but, if space is available, grandparents may also be named. Whilst a full form of address is to be encouraged, the Incumbent has a discretion to approve names by which the deceased was widely known and diminutives in common or regional usage.
- b. Any factual material in the inscription must be accurate.
- c. Inscriptions must be concise, simple and dignified, and may include quotations from Scripture or other appropriate literary sources, subject to approval by the Incumbent. They should be incised, or in relief, and may be painted. Lettering may be picked out in black, gold, silver grey, or white. Matt colours must be used. Hand-cut lettering is encouraged.
- d. The normal expectation is that inscriptions will be in English and in the Roman alphabet. Inscriptions (in part or in whole) in other languages must be accompanied by an agreed translation which must be kept in the parish records.
- e. No new memorials with plastic or other inserted (e.g. lead) lettering may be introduced.
- f. Inscriptions are to appear on one side only.

- g. Additions may be made to an inscription at a later date following a subsequent interment in the same grave or for other suitable reason (for example cremation or death abroad). However, any such alteration must be separately approved by the Incumbent. The lettering, lay-out and wording must be consistent with the original inscription. The Incumbent may permit the memorial to be removed temporarily from the churchyard if this is needed to facilitate the additional inscription.
- h. Photographs or porcelain portraits are not permitted.
- i. Where the stone is to bear any embellishment or symbol other than lettering, this should be fully described in the application; in such cases, the Incumbent may require the applicant to seek a faculty.
- j. A badge or insignia of the Armed Forces of the Crown is permitted provided that the Incumbent has a letter of authority from the branch of the Forces in question.
- k. The Incumbent must not approve a proposed inscription if he or she considers that it is likely to be controversial for any reason or in any other way inappropriate. The Incumbent is encouraged to seek guidance from the Archdeacon or the Diocesan Registry if he or she is concerned by any particular wording or inscription.

Trademarks

14. No advertisement or trademark should be inscribed on a headstone. The mason's name may be inscribed at the side or on the reverse in unleaded letters, no larger than 13mm (1/2in) in height. No QR code may be placed on a memorial without a faculty.

Flowers

15.

- Except where the design of a headstone includes an integral receptacle for plants or cut flowers, they may be placed in a removable container (not of glass), which must be sunk completely into the ground. Flowers should not be wrapped in cellophane.
- Wreaths and cut flowers may be placed in such containers or laid on any grave, but must be removed as soon as they appear to be withered.
- Artificial flowers are not encouraged, and where they are used the Incumbent or the churchwardens may remove them after three months or earlier if they should deteriorate.
- Bulbs may be planted in the soil of the grave.

Other items

16. People sometimes wish to place other items on graves. This is discouraged as items may be stolen or vandalised, and their deterioration can become a source of distress. In any event such items can be removed by the Incumbent or churchwardens after three months (but only after the bereaved have been given an opportunity to do so themselves).

Cremated remains

17. Cremated remains buried in a churchyard should normally be buried without their container. They are to be poured into the ground, from the container in which they are brought to the burial site, by the minister committing them to the earth and then covered with soil. At the discretion of the Incumbent such cremated remains may be buried in a casket or urn provided that it is made of biodegradable material. (This is currently the case in Finningley Churchyard)

18.

- a. The scattering of cremated remains in churchyards is prohibited.
- b. The deposit of cremated remains is permitted in areas which have been designated for that purpose by faculty.
- c. Memorial tablets are only permitted in an area set aside for cremated remains if a faculty has been granted either for an individual or collective commemoration.

Memorials for buried cremated remains

19.

- a. Where cremated remains are buried, memorial tablets may be permitted if they are already found in the churchyard.
- b. Memorial tablets over buried cremated remains should be in natural stone and level with the surface of the ground.
- c. Such memorial tablets should consist of a flat stone 12 x 24 inches.
- d. The practice of installing 'miniature' vertical headstones is not permitted.

- e. Memorial tablets of a different colour or design may be permitted where memorial tablets of the particular colour or design are already common in the relevant part of the churchyard.
- f. In case of doubt, the Incumbent will consult the Diocesan Registrar and may require those proposing to install the memorial to seek faculty approval.
- g. If the introduction of cremated remains into the existing grave of a family member is proposed, the person who commissioned the original memorial (i.e. has Exclusive Right of Burial) must be consulted.
- h. It is always preferable to add an additional inscription to the existing memorial rather than commission a new one.

Repairs, alterations and removals of memorials

20.

- a. The repair of memorials is the responsibility of the family concerned, but PCCs may act if the family cannot be traced or will not act.
- b. Apart from removals in accordance with paragraphs d) and e) below, no memorial may be permanently removed without a faculty. Petitions for a faculty for the removal of memorials will be dealt with on a case-by-case basis.
- c. Faculties may be granted in appropriate cases for the removal or relocation of memorials to enable a churchyard to be properly maintained or to enable the ground to be re-used.
- d. The Incumbent may permit the temporary removal of a memorial for approved alterations to the engravings to be made or for the purpose of repairs.

- e. The Incumbent may allow permanent removals to enable a bereaved family or friends to install an exact like for like replacement, using the same type of stone
- f. The permissions under paragraphs d) and e) may only be given when the Incumbent is satisfied that all those who have an interest in the memorial have been informed and have agreed in writing to the alterations, repairs or like for like replacement.
- g. In the case of doubt the Incumbent will advise those involved to petition for a faculty to permit what is proposed.

Contact Details

Incumbent (Minister)

Rev Neil Redeyoff
The Rectory, Rectory Lane
Finningley
Doncaster
DN93DA

Email: neil.redeyoff@sheffield.anglican.org

Tel: 01302 770240

Sheffield Diocesan Registry

Sheffield Diocesan Registry
Anthony Collins Solicitors
134 Edmund Street
Birmingham
B3 2ES

Email: sheffielddiocesanregistry@anthonycollins.com

<https://www.sheffield.anglican.org/the-diocesan-registry/>

